

**"FLEXORBER HP" by PULSEGUARD**  Since 1979

Typical "FLo" Series Pulsation Damper, with options.  
316L or A20 wetted metal plus PTFE Membrane.

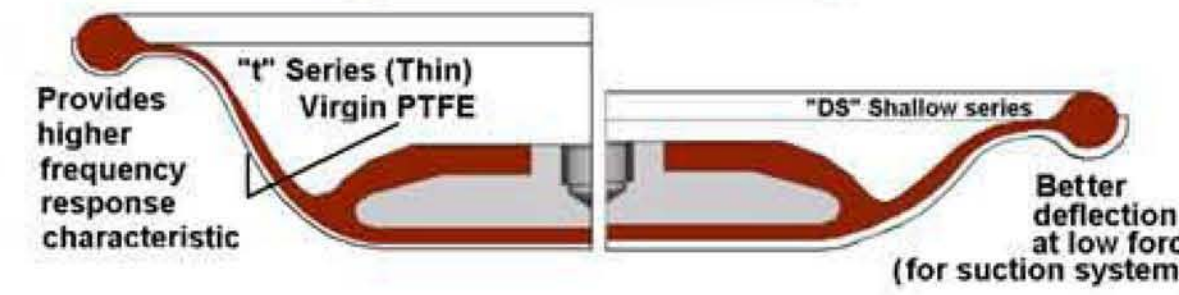
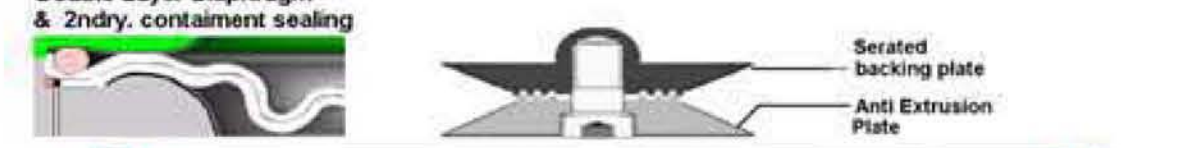
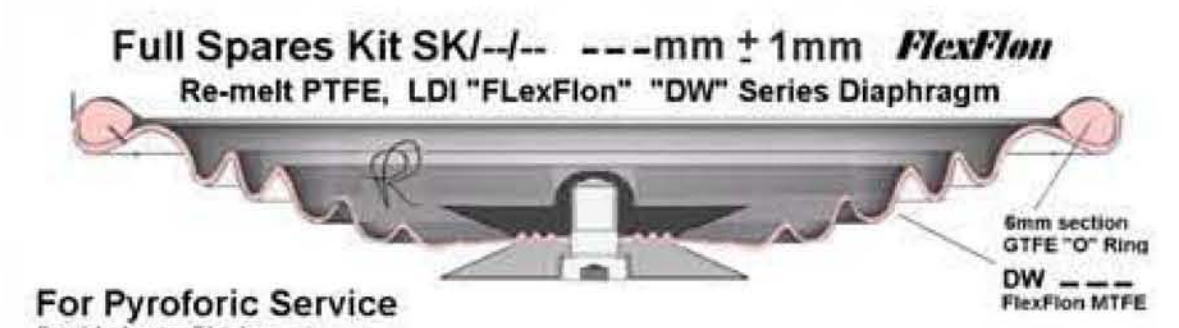
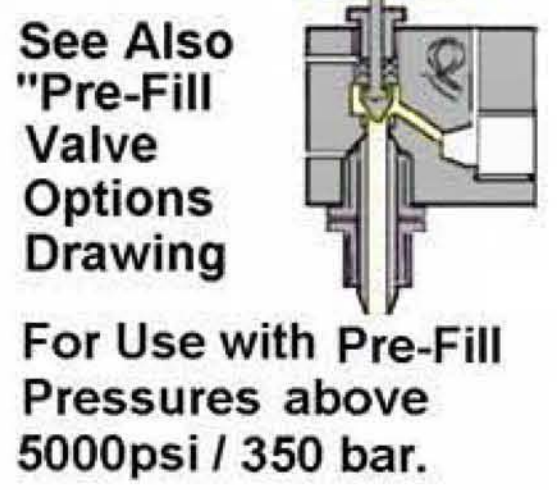
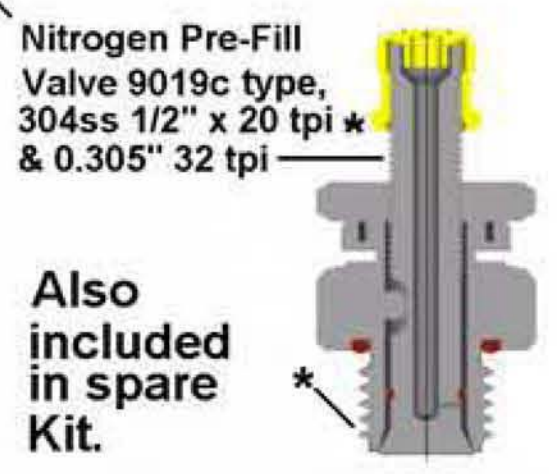
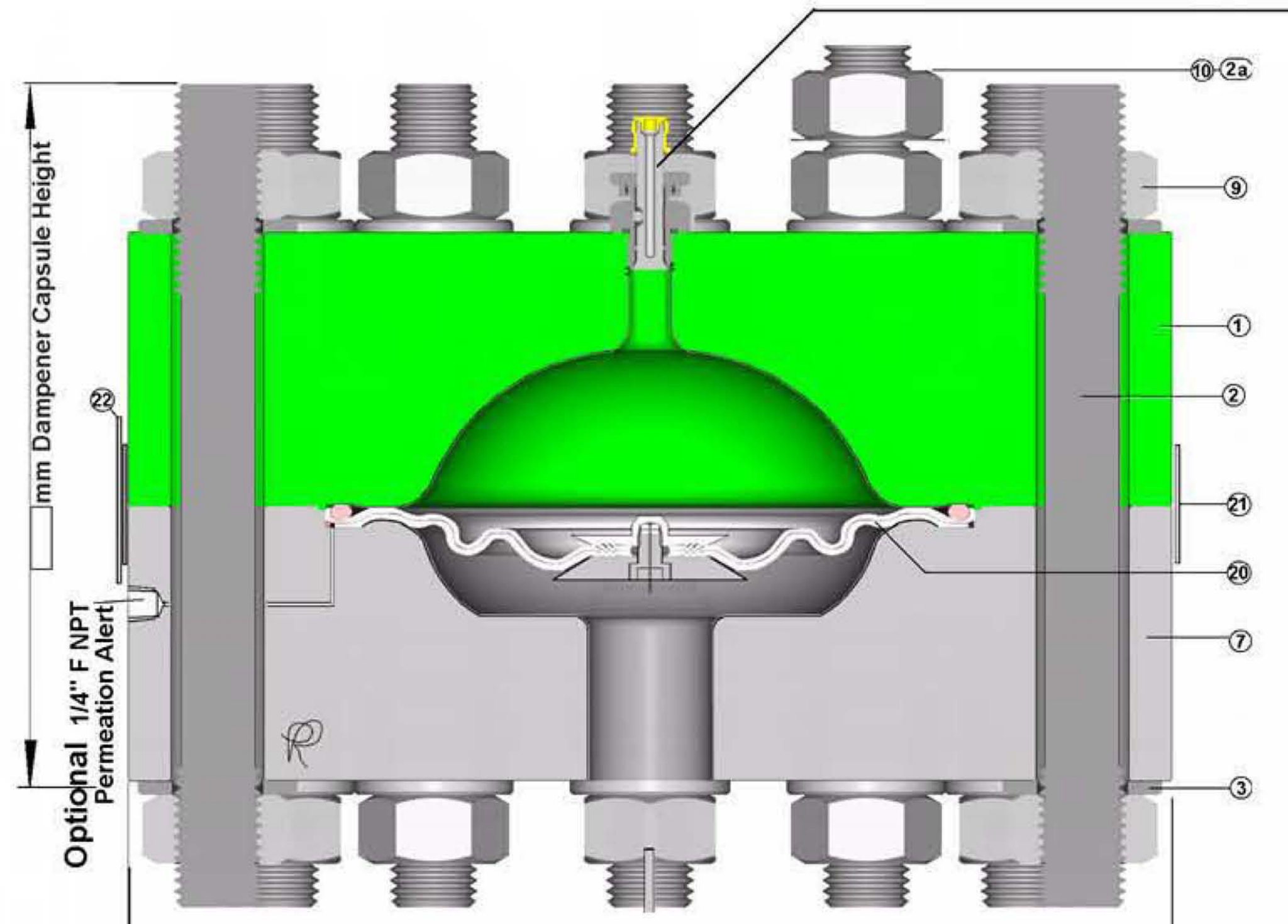

**DECLARATION as required by PED**  
Mandatory Essential Safety Requirement "ESR" state under design 2 at 2.1 the use of: "SAFETY COEFFICIENTS" this can not be complied with because neither EN 5500 nor EN 13445 have any Safety Coefficients.  
Accordingly: It must be a fraud for any notified body to issue a certificate of conformity.

Item Nbr	Description / function	IDENTIFICATION / TRACEABILITY
22	Stainless Steel Data Plate.	Internal "Heat/Cast No" PURCHASE No
21	Split Line Safety Band, Stainless	
20	DW series Diaphragm - Flexflon	
19	Piping base block, up to 4 ports. Above 1" FNPT connections are 37.5 Degree weld bevel, or NPT Male	
18	Face "O" seal	
17	Pressure relief escape groove.	
16	Socket head bolting, 4 equi-spaced 4 by socket heads on PCD	
12	Schedule pipe nozzle,	
10	3 places - All-thread on same Pitch Circle Diameter as boltings	
9	Nuts, 1 for each bolt, 3 per all-thread, provides 1 for mounting	
7	Liquid side. Contact outside bolt circle.	
3	Large, flat washers. 2a	
2	Bolts 9 places. Mounting, long "all-thread" 3 places. with Diameter reduced to thread root diameter	
1	Nitrogen Side, Carbon Steel,	

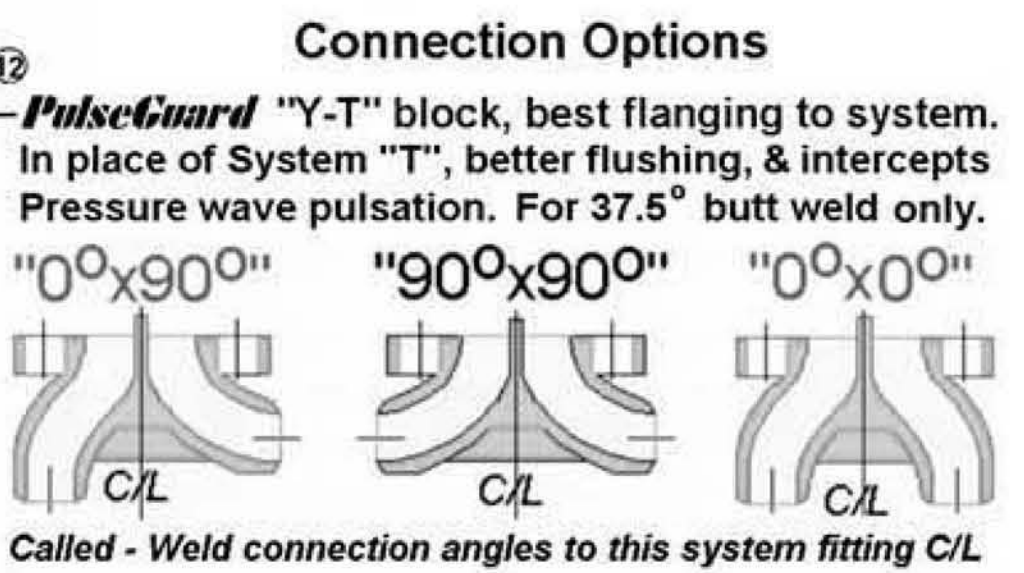
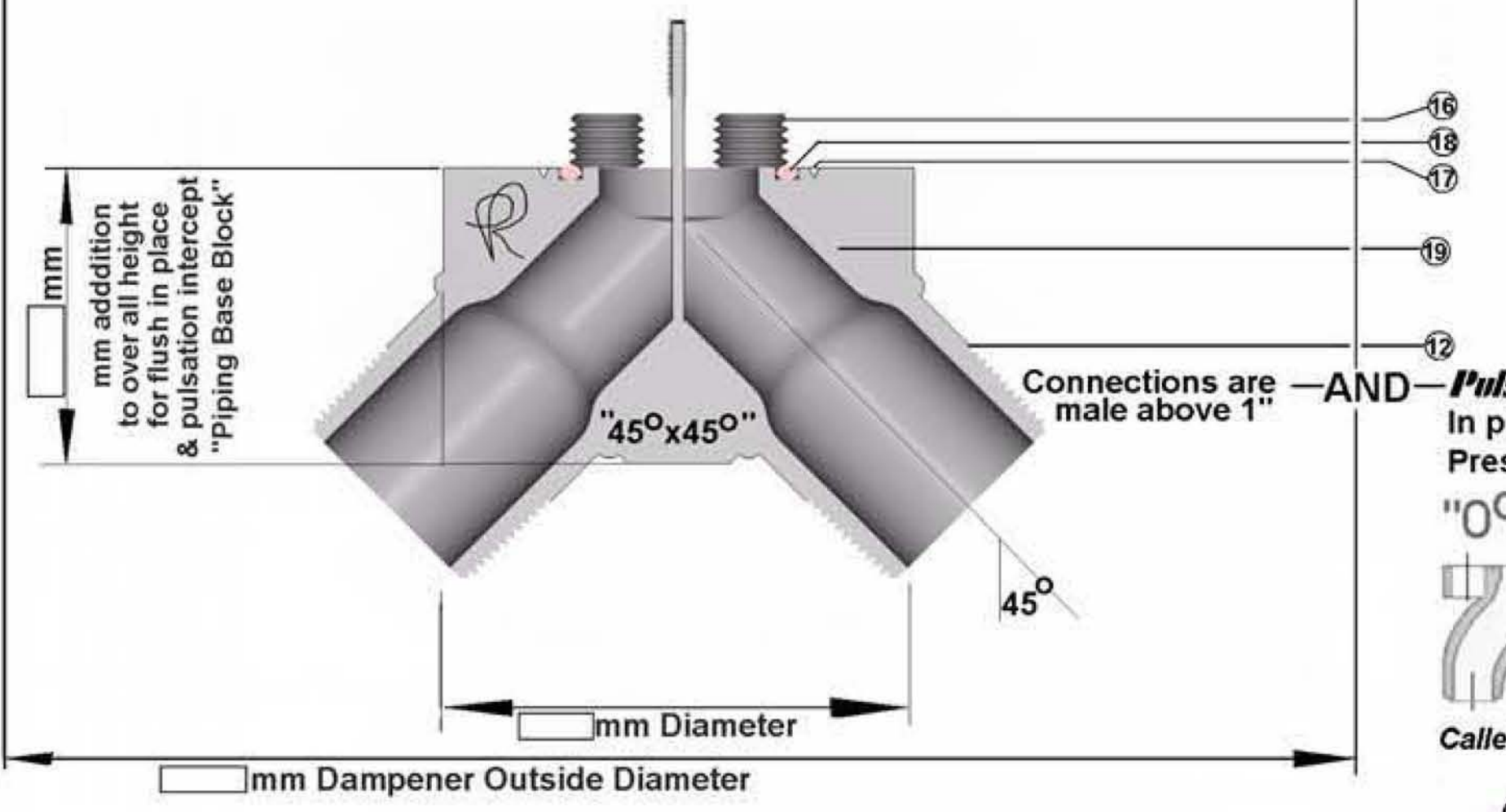

Item Nbr	Description / function	Internal "Heat/Cast No" PURCHASE No
<b>↑ BILL OF MATERIALS ↓</b>		
Scale : Please do not print without "MAINTAIN ASPECT RATIO" on, Use A3 paper on A3 paper, Landscape, 420mm wide		
Part Nbr. / Drawing Ref : _____ Date _____ th 200__ Rev Nbr 1		
FLO/ss/ _i/ _p/DW _/ "O"/316L-PTFE + PB _"x_" M NPT 316L		

**PulseGuard** <http://www.PulseGuard.com>  
<http://www.PulseGuard.co.uk>  
**PulseGuard für Deutschland** [www.pulsationdaempfer.com](http://www.pulsationdaempfer.com)  
**PulseGuard, de langue Francaise** [amortisseurs-de-pulsations.com](http://amortisseurs-de-pulsations.com)  
**PulseGuard, en Espanol / sud Amerique** [amortiguador-de-pulsaciones.com](http://amortiguador-de-pulsaciones.com)  
**PulseGuard, dlya Russkogovoryaschih** [pulsations-dampfer.com](http://pulsations-dampfer.com)

PulseGuard is the USA registered trade mark of PulseGuard Inc.  
PulseGuard is the UK registered trade mark of PulseGuard Ltd.  
**UK --44(0)161-480-9625 USA ---1910-270-2737**