

Pulsation Damper Bladder liquid inside Stainless wetted Medium Pressure

"PIPEHUGGER HP" by PULSEGUARD Typical "Phr" Series Pulsation Damper, with options.

Since 1980

316L, or A20, Tit2, Hasteloy etc wetted metal parts + EP, Nitrile, Hypalon, Fluorel etc bladder.



For Use with Pre-Fill Pressures above 5000psi / 350 bar.

PED CONFORMITY DECLARATION as required by the PED ESSENTIAL SAFETY REQUIREMENTS "ESRs" state at 2 Design, under 2.1 the use of "SAFETY COEFFICIENTS". As Euro Norm 5500, and harmonised pressure vessel code 13445 do not have proven safety coefficients to apply, NO ONE complies with ESRs. Above statement applies to us also. Any documents of conformity issued particularly to ISO 9001-2000 holders by "Notified Bodies", must be a fraud. ALL Dampers are NON-CONFORMING

We are able to warrant safety when following our own 30 year proven methods :-
We can not accept end user statement that design pressure is working pressure

Where Allowable Working Stress = S
Design Pressure P = MAWP + 10% + 15%
Joint Efficiency = E RV RVAcc
RV is for relief safety valve set pressure
RVacc for relief valve accumulation pressure
E is 1.0 No Welds, or radiographed.
E is 0.7 Welded but not radiographed.

$$T = \frac{Design\ Pressure \times Radius\ Internal}{S(From\ Pt.\ II\ D\ 1992) \times E} - (0.6P)$$

The ASME have increased allowable working stresses, enabling cheaper less safe vessels, so that their "U" certification business can be expanded against international competition, and the income of ASME International increased.

Concurrently European Pressure Equipment Directive, the "DEP" enforced by criminal law, has no "SAFETY COEFFICIENTS" in its "ESRs" -Essential Safety Requirements- approved for soft cyclic duty snubber dampers, whilst also allowing ductility as low as 14%.

These codes prevent code dampers being waranteed safely suitable for purpose.

A full Spares Kit Consists of : Pt Nbr. SK/-----

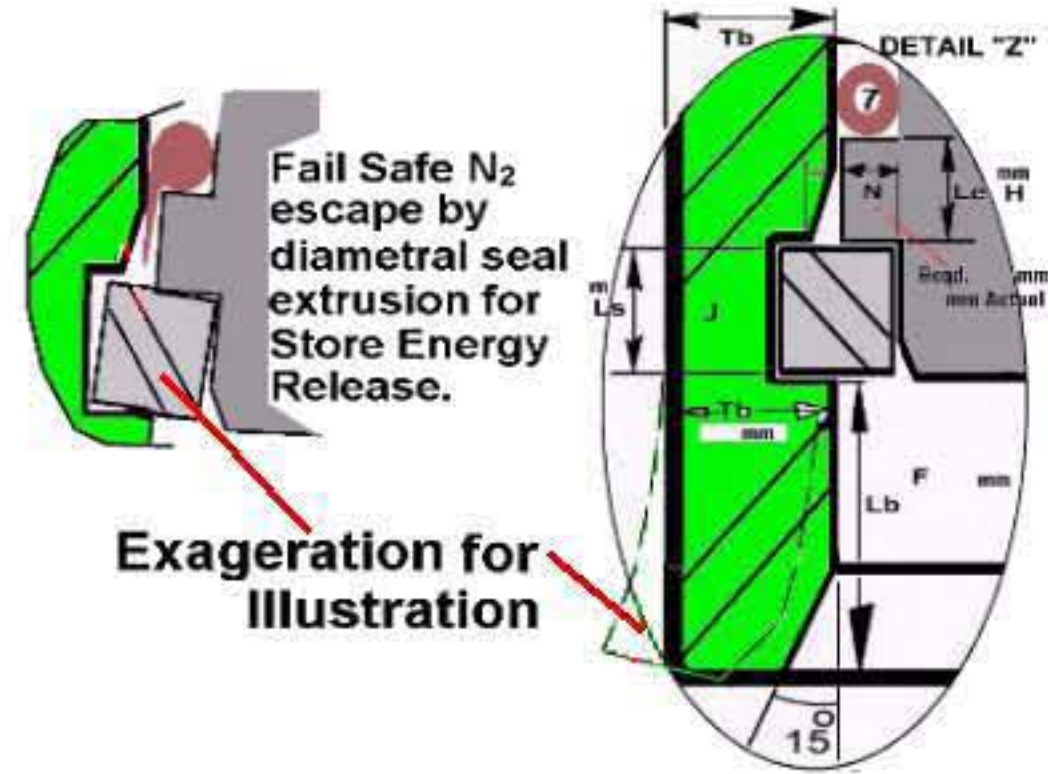
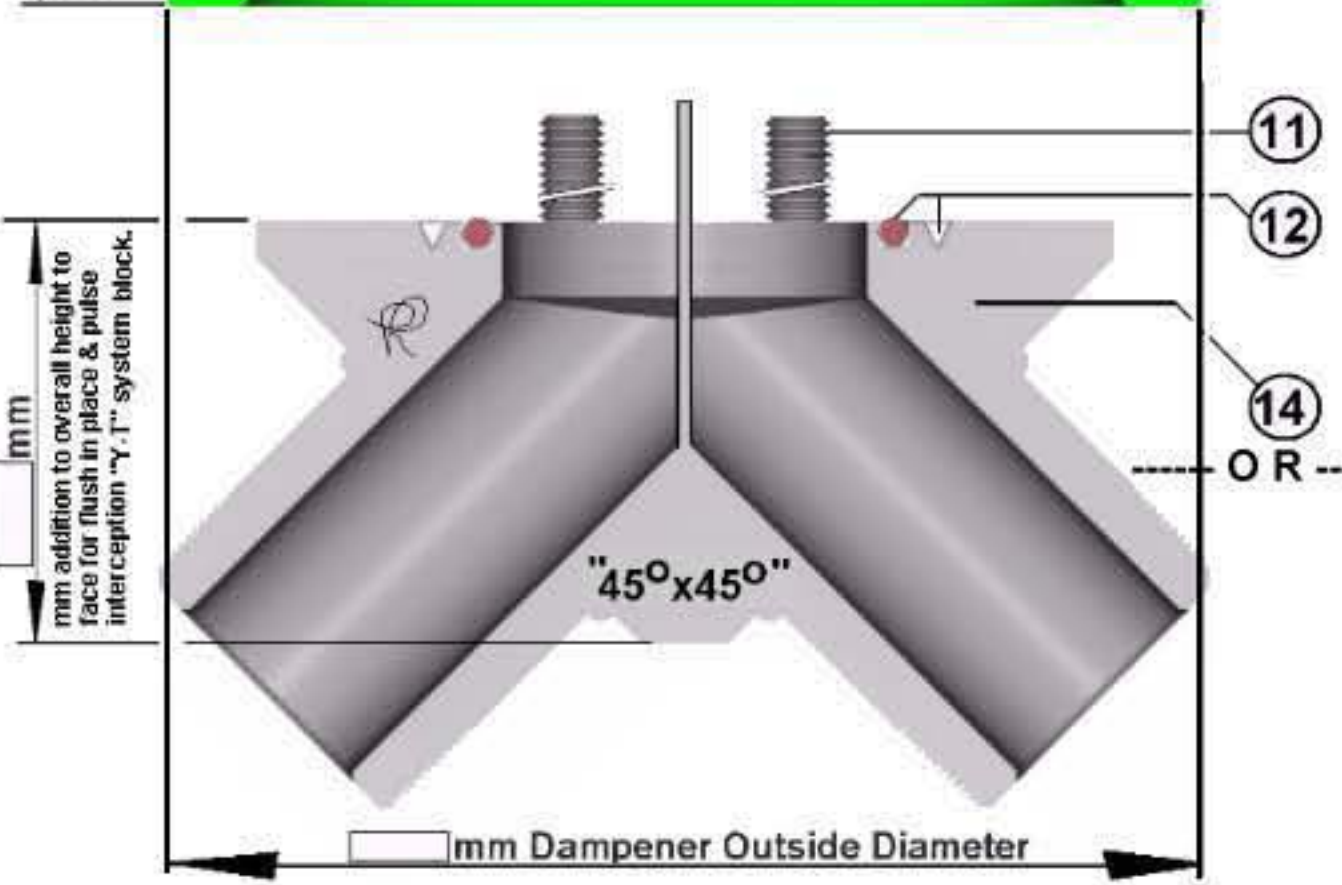
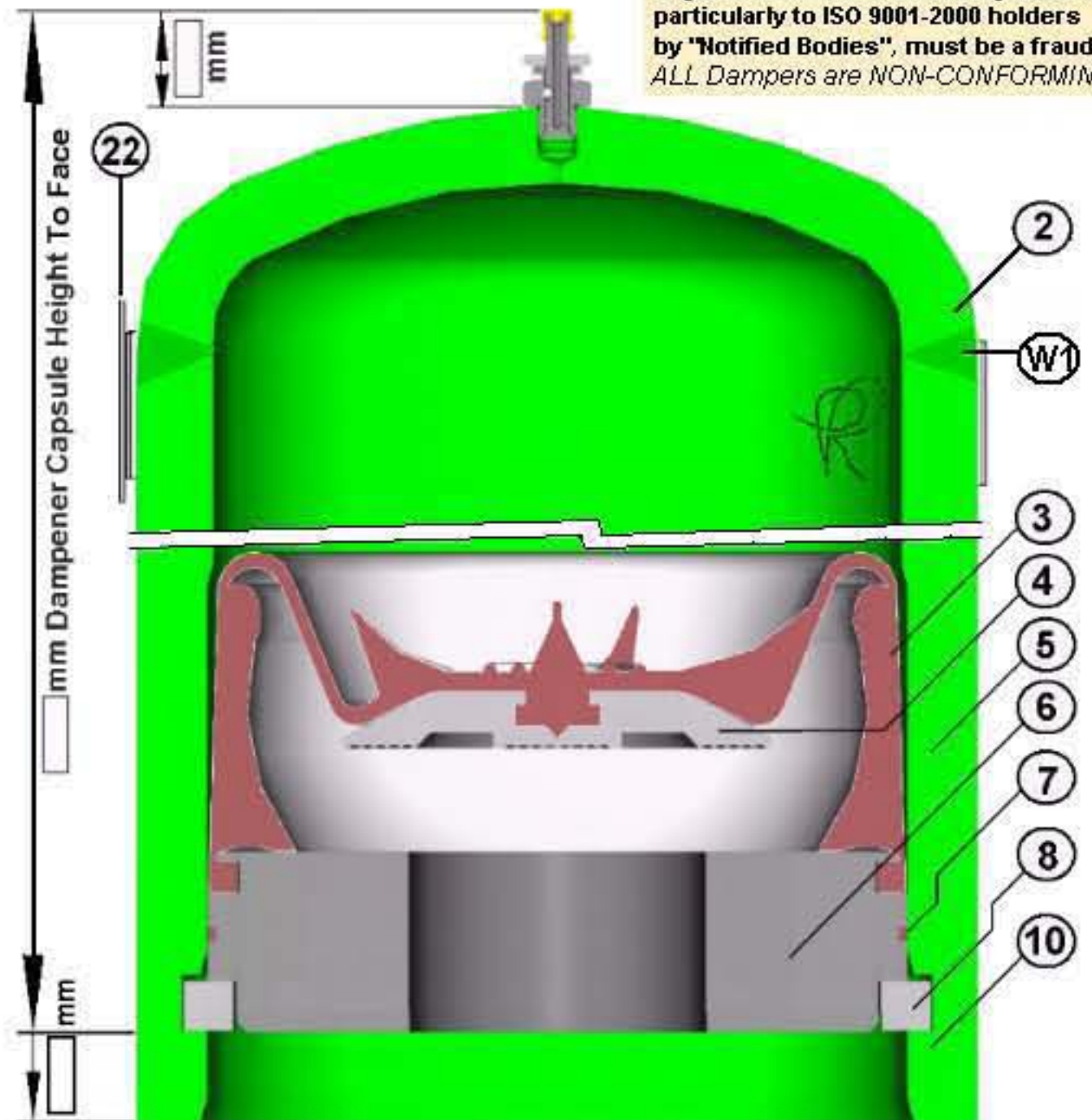
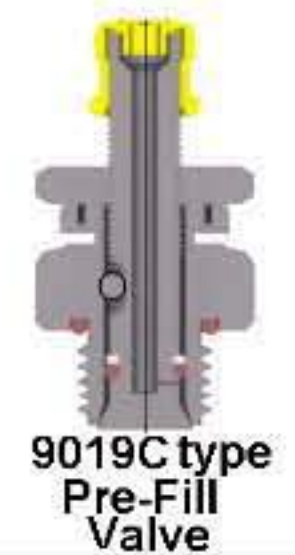
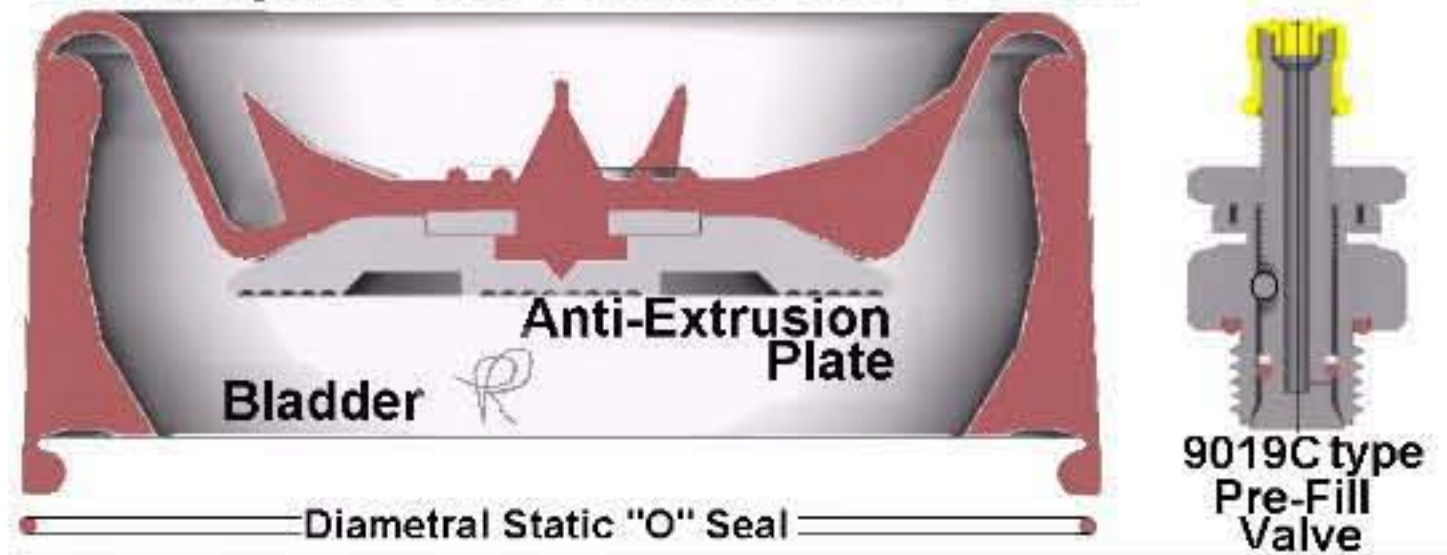

PulseGuard "Y-T" block, best flanging to system. In place of System "T", better flushing, & intercepts Pressure wave pulsation. For 37.5° butt weld only.

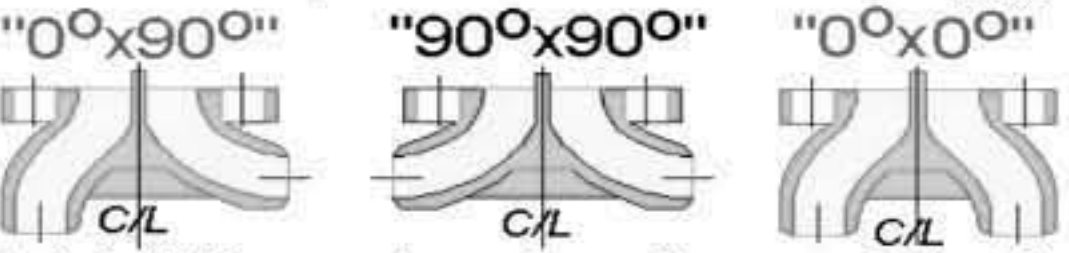

Called - Weld connection angles to this system fitting C/L
PulseGuard "Top-Hat" Allows flushing of pipe "crud" and pipe hydro-test before damper bolt on. May also replace damper during service.

Item Nbr	Description / function	Internal "Heat/Cast No" PURCHASE No
W1	GTAW Argon Purge Full Penetration Root & Fill /309ss	IDENTIFICATION / TRACEABILITY
22	Stainless Data Plate on stainless banding.	
18		
17		
16		
15	Stainless Data Plate on stainless banding.	
14	"PB 45°x45°" machined from billet	
13	NOT SHOWN Retaining Plate used with small bases on large dampners	
12	Face "O" seal with escapement groove for any leakage pressure build up.	
11	Socket Head Cap Screws, 4 Places. Diam. Lgth UH	
10	Open Mouth "Skirt" from pipe. As 5 Below.	
8	Lock Ring, tamper-proof, 3 segments of circle.	
7	"Base Plug" - static diametral seal "O" ring	
6	End Closure / "base plug" - liquid contact part.	
5	Seamless Body	
4	Anti Extrusion Plate	
3	Liquid Bladder "D--- y---" (mm Dia x mm high)	
2	2:1 SE Head	
1	Nitrogen Pre-Fill Valve 9019c type,	

Item Description / function Internal "Heat/Cast No" PURCHASE No
↑ BILL OF MATERIALS ↓

Scale : Please do not print without "MAINTAIN ASPECT RATIO" on, Use A3 paper on A3 paper Landscape 420mm wide
Part Nbr. / Drawing Ref : Date th 200- Rev Nbr 1
Phr/ / _/ _/ _/ p/D _/ "O"/316L- _ + PB _ "x" M NPT 316L

PulseGuard <http://www.PulseGuard.com>
PulseGuard für Deutschland <http://www.PulseGuard.co.uk>
PulseGuard, de langue Francaise www.pulsationdaempfer.com
PulseGuard, en Espanol/ sud Amerique [amortiguador-de-pulsaciones.com](http://www.amortiguador-de-pulsaciones.com)
PulseGuard, dlya Russkogovoryaschih [pulsations-dampfer.com](http://www.pulsations-dampfer.com)

PulseGuard is the USA registered trade mark of PulseGuard Inc.
 PulseGuard is the UK registered trade mark of PulseGuard Ltd.
UK --44(0)161-480-9625 USA ---1910-270-2737